

First RI Gimmicks

SKILL LEVEL: BEGINNER-NOVICE

It is very common to have a gimmick on the first route instruction (RI). Usually, the gimmick involves RI 1 not coming into effect. Most often, this is because RIs come into effect when you complete (that is, execute or delete) the previous RI. With no RI to precede it, RI 1 doesn't come into effect. Furthermore, DRI usually deletes the RI in effect, so you can't DRI RI 1 when there is no RI in effect

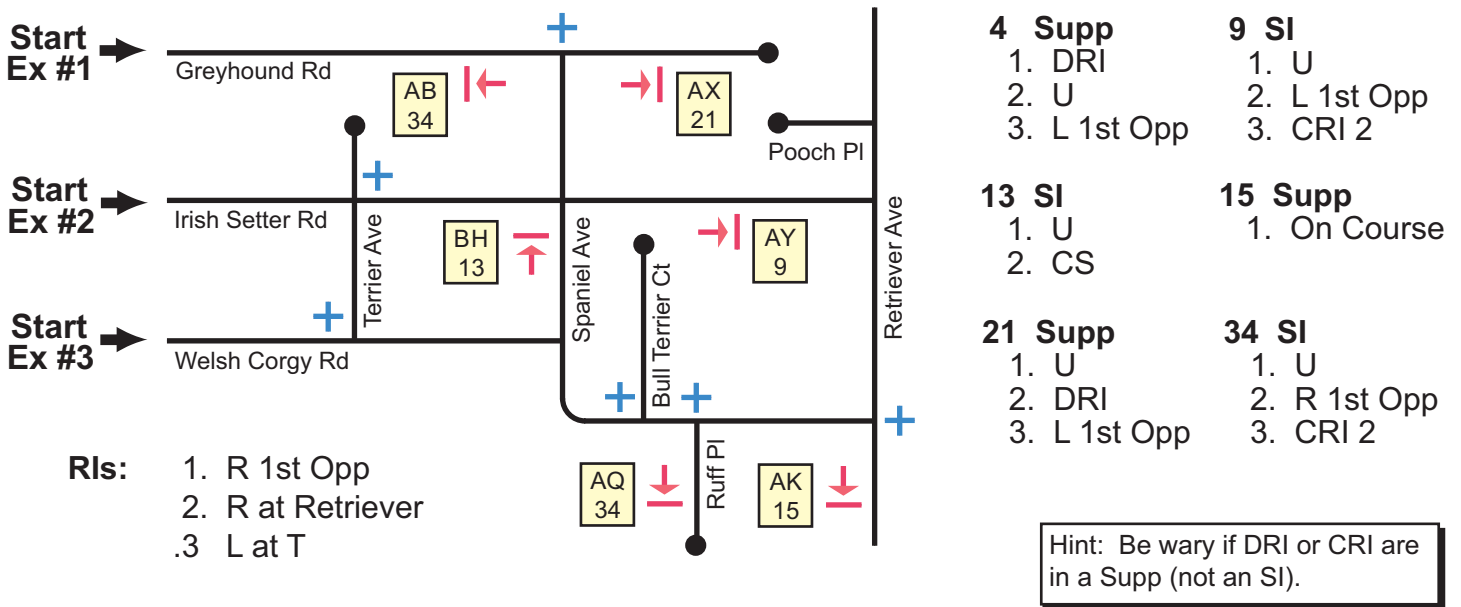
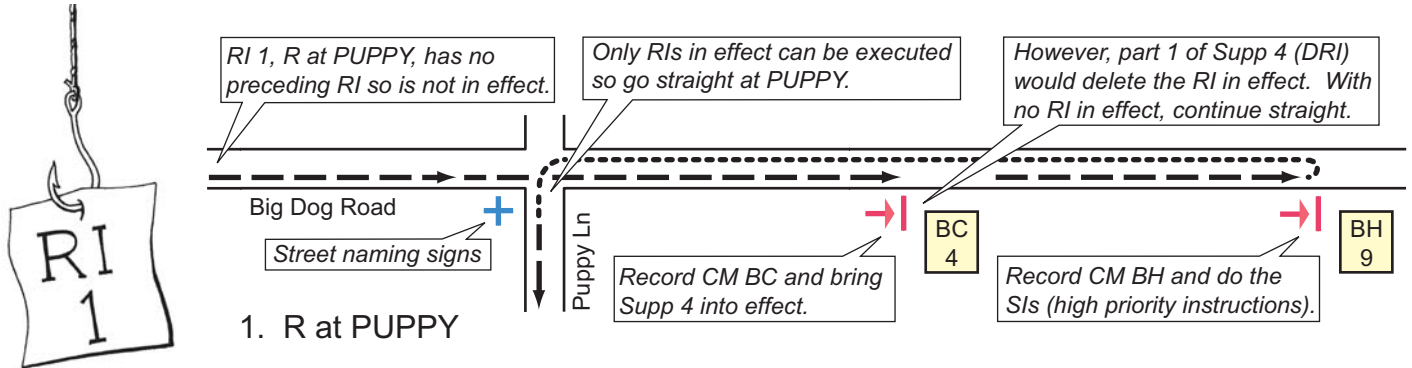

Using the above map, Supps, RIs, run the route with these GIs:

L at otherwise uninstructed T intersections.

Exercise #1 Add to the above GIs: RIs come into effect upon completion of the immediately preceding RI.

Exercise #2 Add to the above GIs: RIs come into effect upon completion of the immediately preceding RI. The exception is RI 1 which comes into effect after you pass "Terrier."

Exercise #3 Replace the above GIs with: The lowest numbered, uncompleted RI is the RI in effect.

Hint: Watch for RI 1 to come back into effect if it is something that can be done in many places like "R 1st Opp" or "L at STOP."

Hint: Look to see if there is an "exception" if "immediately preceding" is used for RIs. This may allow you to execute RI 1.

Answers. What you should have done:

Exercise #1: Deny RI 1 as it is not in effect to get AX. Do the U from Supp 21 to get AB but not the DRI since RI 1 can only be deleted if it is in effect. Execute to complete RI 2 and then get the on course CM AK down Retriever Ave.

Exercise #2: There is an "exception" sentence describing how RI 1 comes into effect. No reason to get AY as RI 1 is good. However, RI 1 comes back into effect when you pass Bull Terrier so get AQ on Ruff. RI 2 is good and so is AK.

Exercise #3: With completely different GIs, RI 1 is good but RI .3 can be done instead at Spaniel to get BH. This is because .3 is the lowest numbered RI. CS by Welsh Corgy and do RI 1 down Ruff to get AQ. Do RI 2 and get AK.

SI: There are NO tricks or gimmicks in these worksheets. Everything here refers to the typical rallye only, and is not part of any rallye in particular. For more rallye information and tips visit www.therallyeclub.org. End SI. rev. 08-23-05 RBS